

粘胶正装款
Bonding Type Front Install

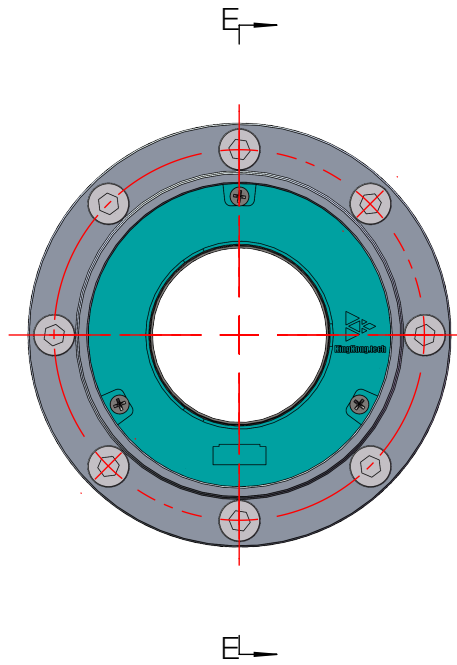

E-E

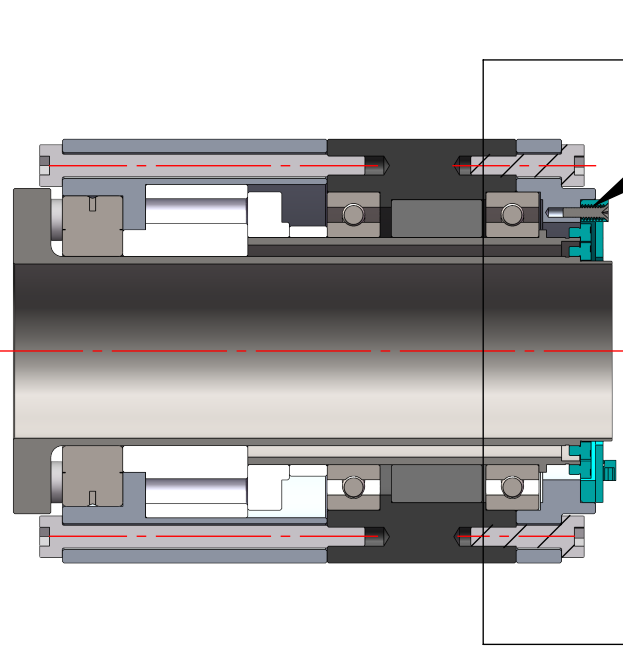

1.4 ±0.2 (G)
轴向定位：转子顶面距定子底面
(Axial positioning: distance between the top surface of the rotor and the bottom surface of the stator)

此孔为M2螺纹孔，便于定子取出
(This hole is an M2 threaded hole for easy removal of the stator)

采用胶粘连接（连接胶建议乐泰243）
Use adhesive connection
(recommended adhesive is Loctite 243)
安装调试时，建议使用乐泰222固定
方便拆装调试
When installing and debugging,
it is recommended to use Loctite 222
for fixation Easy disassembly and debugging

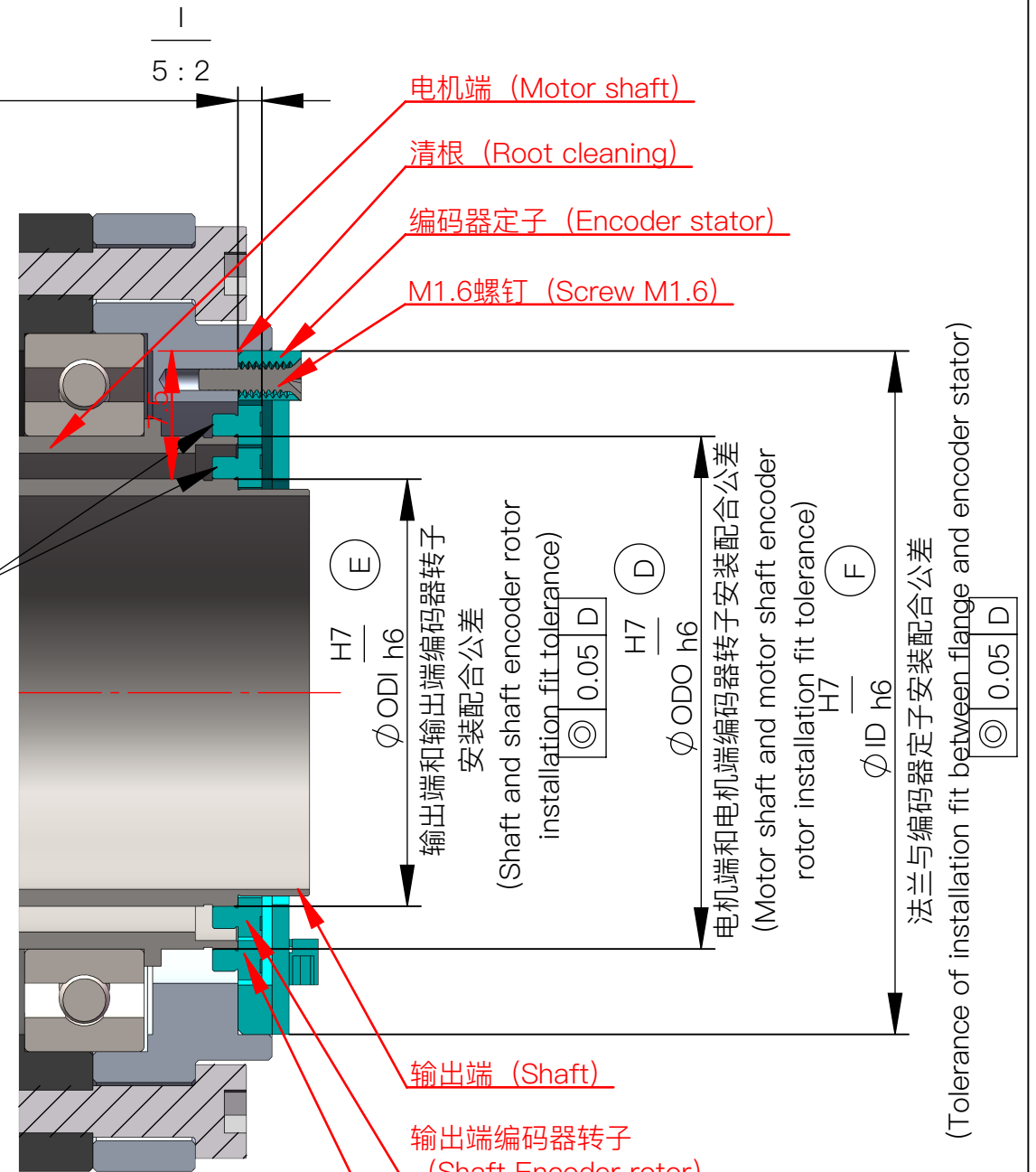

使用配套工具安装、拆解转子示意：
(Diagram of using matching tools to install and disassemble the rotor)

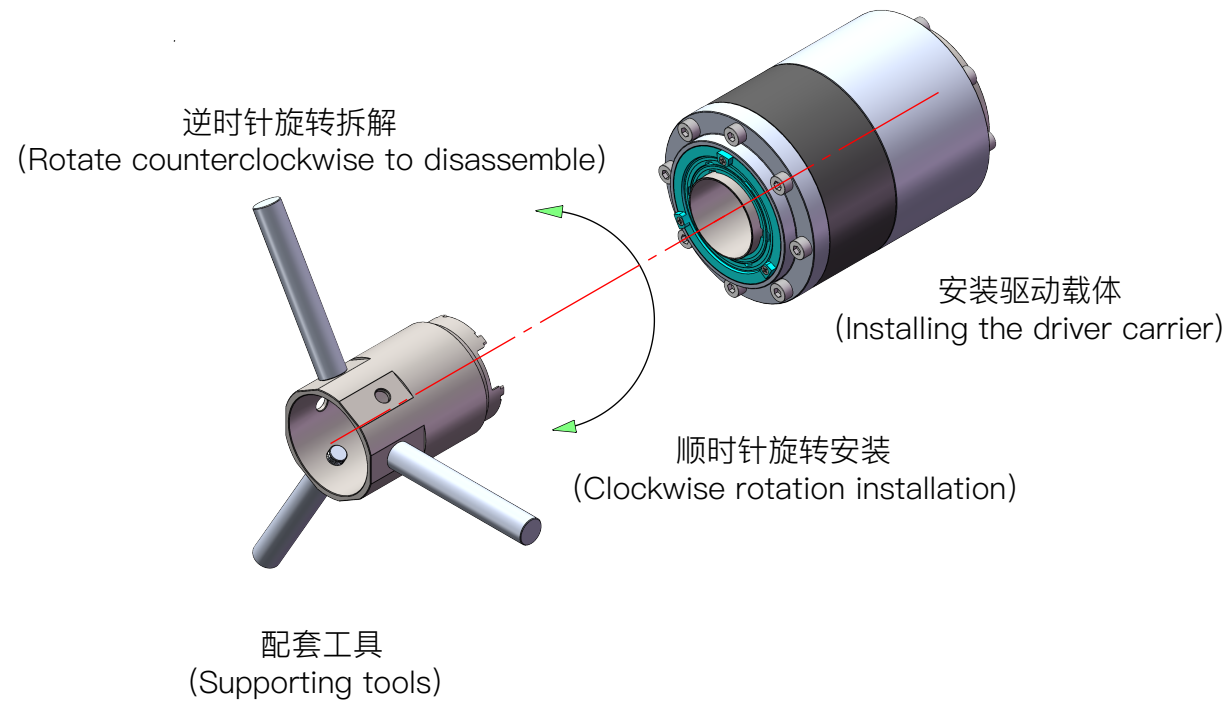

共四个公差安装尺寸，分别定位了 (There are four tolerance installation dimensions, which are located separately) :

- 1、输出端编码器转子的径向位置 (Radial position of the Shaft Encoder rotor) (D) ;
- 2、电机端编码器转子的径向位置 (Radial position of the Motor shaft Encoder rotor) (E) ;
- 3、编码器定子的径向位置 (The radial position of the Encoder stator) (F) ;
- 4、编码器转子与编码器定子相对轴向位置 (Relative axial position between Encoder rotor and Encoder stator) (G) ;

可尽可能还原出厂标定时位置状态已得到最佳数据精度
(It is possible to restore the position status during factory calibration as much as possible to obtain the best data accuracy) .

北京金钢科技有限公司
KingKong Technology

DPT系列设计安装建议
DPT series design and
installation suggestions

比例 (scale) : 1:1