

螺纹正反装款  
Thread Type Front/Back Install

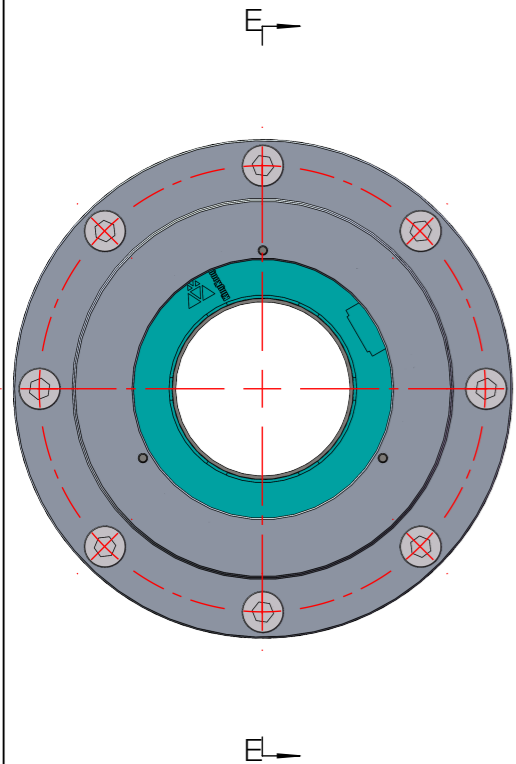

E-E

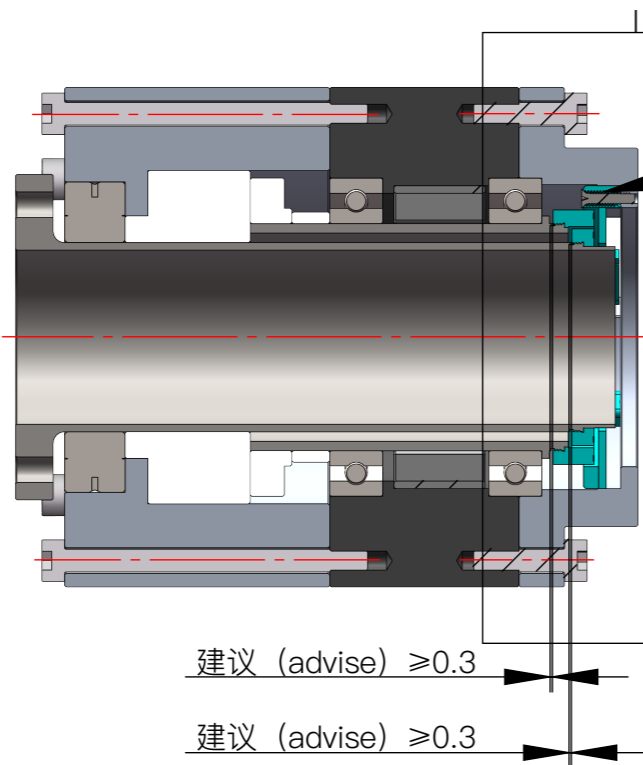

轴向定位：转子顶面距定子底面  
(Axial positioning: distance between the top surface of the rotor and the bottom surface of the stator)  
此孔为M2螺纹孔，便于定子取出  
(This hole is an M2 threaded hole for easy removal of the stator)  
同时也可通过M2螺钉反向固定定子  
At the same time, the stator can also be fixed in reverse with M2 screws

MTO (电机端编码器转子安装螺纹)  
(Motor shaft encoder rotor installation thread)

installation thread)

根据工况选择螺纹胶防松  
(Select thread sealant to prevent loosening according to working conditions)

Ø MTI (输出端编码器转子安装螺纹)  
(Shaft encoder rotor installation thread)

installation thread)

根据工况选择螺纹胶防松  
(Select thread sealant to prevent loosening according to working conditions)

电机端 (Motor shaft)

编码器定子 (Encoder stator)

清根 (Root cleaning)

M1.6螺钉 (Screw M1.6)

输出端 (Shaft)

输出端和输出端编码器转子安装配合公差  
(Shaft and shaft encoder rotor installation fit tolerance)

H7

Ø ODI h6

ⓔ

ⓓ

ⓕ

ⓕ

ⓕ

ⓕ

ⓕ

ⓕ

ⓕ

ⓕ

ⓕ

ⓕ

ⓕ

ⓕ

ⓕ

ⓕ

ⓕ

ⓕ

ⓕ

法兰与编码器定子安装配合公差  
(Tolerance of installation fit between flange and encoder stator)

ⓕ

ⓕ

ⓕ

ⓕ

ⓕ

ⓕ

使用配套工具安装、拆解转子示意：

(Diagram of using matching tools to install and disassemble the rotor)

逆时针旋转拆解  
(Rotate counterclockwise to disassemble)

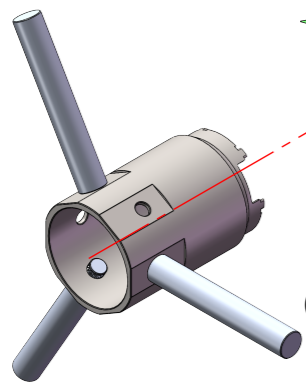

配套工具  
(Supporting tools)

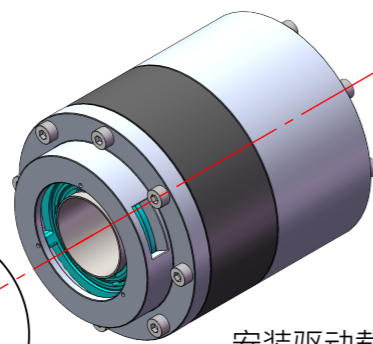

安装驱动载体  
(Installing the driver carrier)

顺时针旋转安装  
(Clockwise rotation installation)

防松螺纹胶建议乐泰243  
Suggestions for anti loosening thread glue: Loctite 243

安装调试时,建议使用乐泰222固定  
方便拆装调试

When installing and debugging, it is recommended to use Loctite 222 for fixation Easy disassembly and debugging

输出端编码器转子  
(Shaft Encoder rotor)

电机端编码器转子  
(Motor shaft Encoder rotor)

共四个公差安装尺寸，分别定位了 (There are four tolerance installation dimensions, which are located separately) :

- 1、输出端编码器转子的径向位置 (Radial position of the Shaft Encoder rotor) ⓓ ;
- 2、电机端编码器转子的径向位置 (Radial position of the Motor shaft Encoder rotor) ⓔ ;
- 3、编码器定子的径向位置 (The radial position of the Encoder stator) ⓕ ;
- 4、编码器转子与编码器定子相对轴向位置 (Relative axial position between Encoder rotor and Encoder stator) ⓖ ;

可尽可能还原出厂标定时位置状态已得到最佳数据精度  
(It is possible to restore the position status during factory calibration as much as possible to obtain the best data accuracy) .

北京金钢科技有限公司  
KingKong Technology

DPT系列设计安装建议  
DPT series design and installation suggestions

比例 (scale) : 1:1